

## FuelX Autotune- Yamaha R15 V.3

<b>Document Version</b>	1	<b>Release Date</b>	14 Sep 2021
-------------------------	---	---------------------	-------------

<b>Application information</b>	<b>FuelX</b>
Vehicle	<b>Yamaha</b>
Model	<b>R15 V.3</b>
Year of manufacture	<b>2018-2019</b>

**Note:**

- Read through all instructions before installation and use.
- Ensure that the bike is switched off and the key is out of the ignition before proceeding with the installation.
- Some parts of the bikes might be hot/sharp and may cause burns/cuts. Proceed with extreme caution or wait until the bike has cooled down. Always wear safety gloves.
- When the installation is complete, make sure to secure the wiring loom away from the movable parts or components which tends to heat up during the normal operation of the vehicle at any chance.
- FuelX is intended for motorsport use on a closed course, please check with your local laws before using this product. Race Dynamics is not liable for consequences arising out of using the product.

**Support:**

Call: +1 267 214 9292 / +91 9606 044 178

WhatsApp: +91 9606 044 178

E-Mail: [support@powertronicecu.com](mailto:support@powertronicecu.com)

Website: [www.powertronicECU.com](http://www.powertronicECU.com)

<b>SL No</b>	<b>Chapter</b>	<b>Page</b>
1	About FuelX and Kit Contents	3
2	Fuel Variants	4
3	FuelX Connectors	5
4	FuelX Installation	7
5	FuelX Configuration	14

## FuelX

FuelX is an electronic, plug-in, fuel-injection optimizer for modern engines. It either enriches or decreases the AFR in all operating regions according to the rider requirement. It autotunes the engine to best operational parameters, constantly monitoring, learning, and adapting to the engine condition, wear and tear, riding style, add-ons (such as air filter and/or exhaust), etc as well as the environmental conditions such as temperature, humidity, altitude, etc. always ensuring the engine performs in the safest and most optimal zones.



### FuelX kit contains the following items

- FuelX Module
- Wiring Harness
- Handlebar map switch (Pro version only)
- Zip ties
- Decals
- Quick start guide and Warranty card



Image 1.1

## 2. FuelX Variants:

### FuelX Pro

The FuelX Pro variant has 10 maps that can be changed depending upon the preference of the rider. For the Pro version, the Fuelx contains an additional connector (Refer Image 2.3) for the Handlebar Map switch(Refer Image 2.2)



Image 2.1



Image 2.2

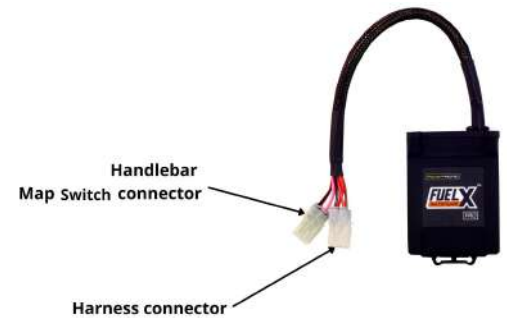

Image 2.3

### FuelX Lite

The FuelX Lite variant has a single autotune map and only one connector for harness.



Image 2.4

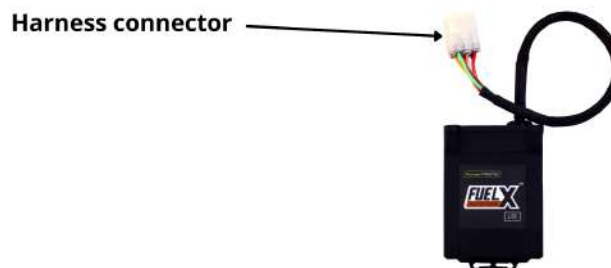

Image 2.5

### 3. FuelX Harness Connectors

The harness contains only the Lambda connector (O<sub>2</sub>).



Image 3.1

The type and number of connectors may vary depending on the vehicle, year of manufacture, and the number of cylinders. Examples of different types of Lambda sensor connectors are shown below.

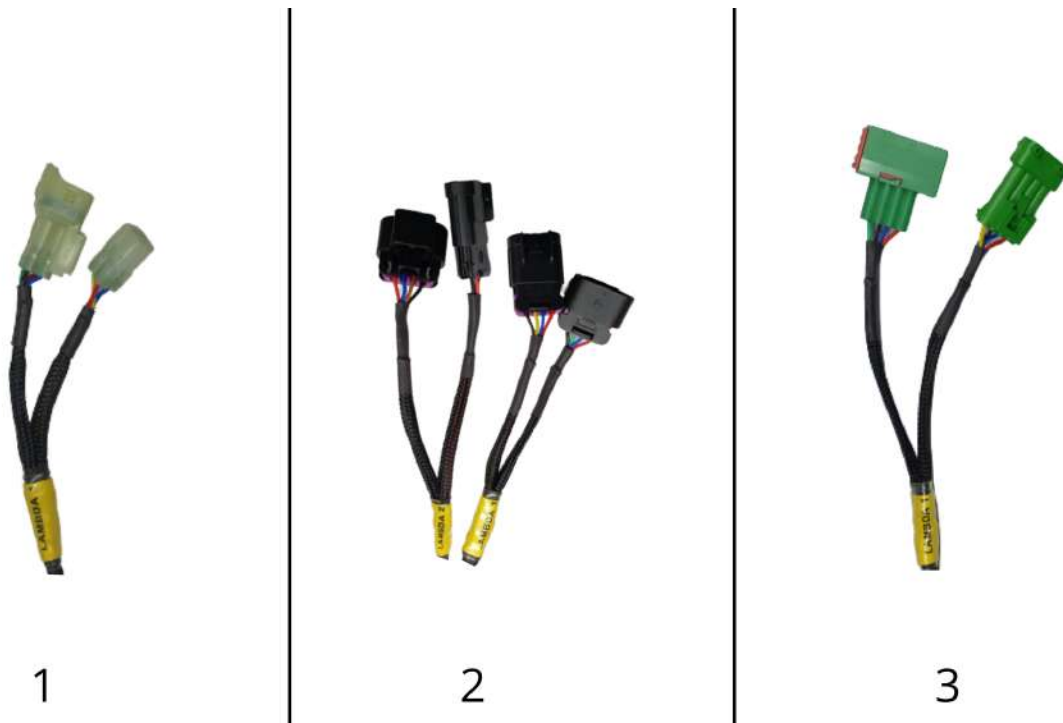

Image 3.2

The FuelX is connected between the Lambda sensor connector and the ECU. The male connector of FuelX, connected to the female of the Lambda sensor and vice versa.

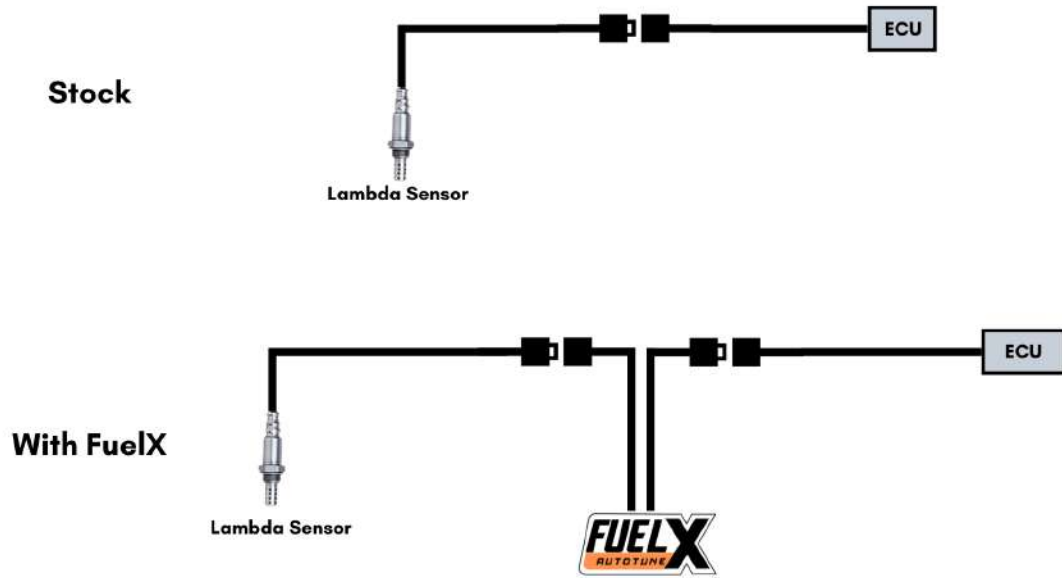

Image 3.3

#### 4.1 Removing panels, fairing

Begin at the left side of the bike.

Image 1 and image 2 Reference for Lambda Sensor location.

Park the bike using the center stand on a level surface (Or a paddock stand).

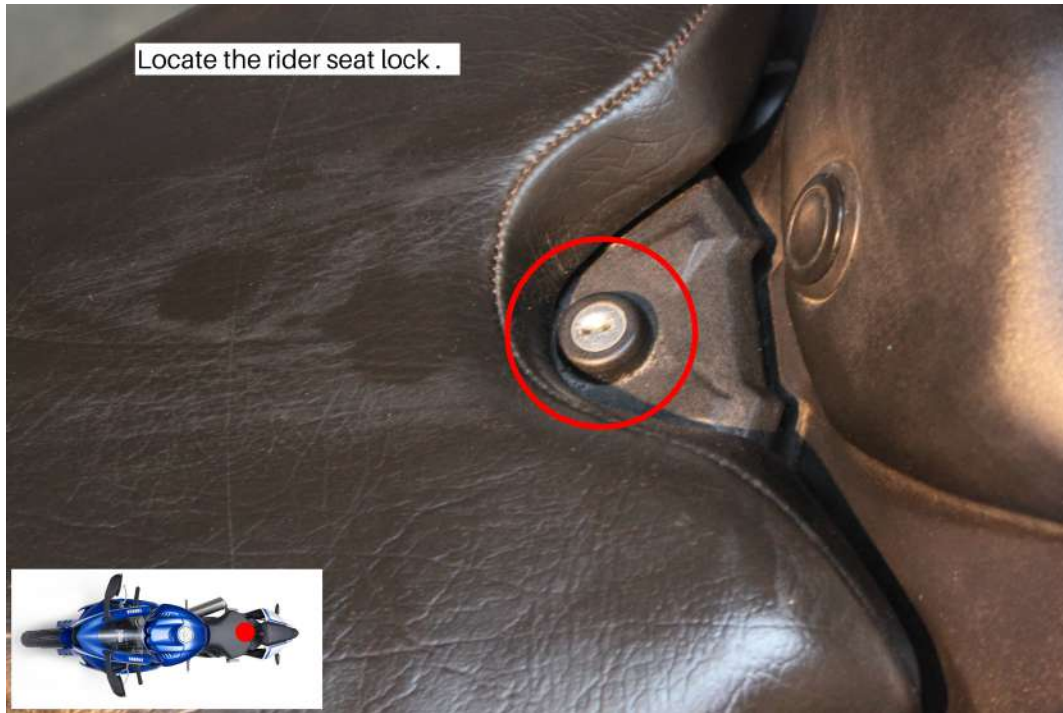

Image 1



Image 2

**4.1.1** Locate the rider seat lock shown in **Image 3** and unlock the rider seat. Refer **Image 4**.



**Image 3**



**Image 4**



4.1.2 **Image 5** shows how the rider seat detached.



**Image 5**

4.1.3 Locate and unscrew the side screw using a Phillips-head screwdriver. Refer **Image 6**.



**Image 6**

4.1.4 After removing the screws, gently detach the panel.



Image 7

4.1.5 Refer the [Image 7](#) to locate the Lambda Sensor Connector

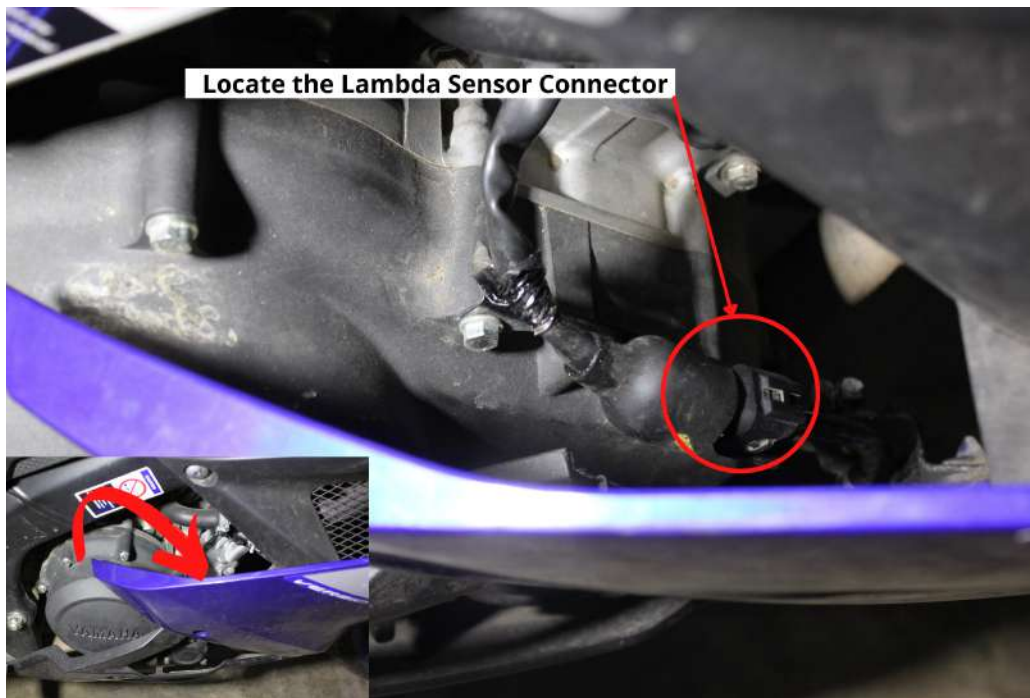

Image 8

**4.1.6** Locate the Lambda Sensor Connector and disconnect the connectors (**Image 9**)



**Image 9**

**4.1.7** Connect the FuelX male connector to Stock female connector refer to image 10



**Image 10**

**4.1.8** Connect the FuelX female connector to Stock male connector refer **Image11**



**Image 11**

**4.1.9** Secure the harness away from general heating areas by attaching it to the chassis or frame using the zip ties provided wherever necessary. Refer **Image 12**



**Image 12**

**4.1.10** Route the harness through the frame. Refer **Image 13**



**Image 13**

**4.1.11** FuelX module positioning and harness routing Refer **image 14**

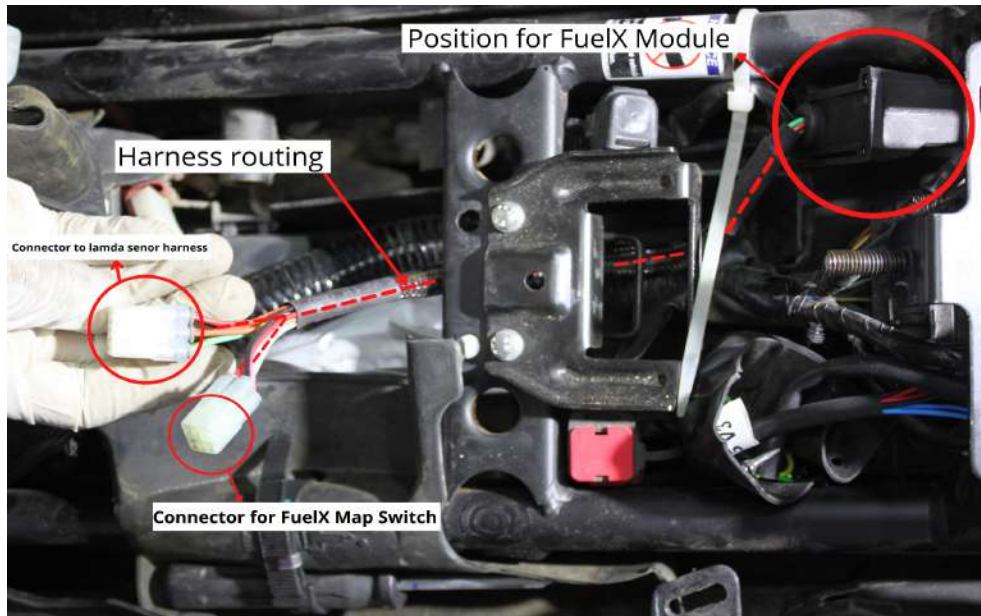

**Image 14**

#### 4.1.12 Connecting FuelX Male and Female connectors Refer **Image 15**

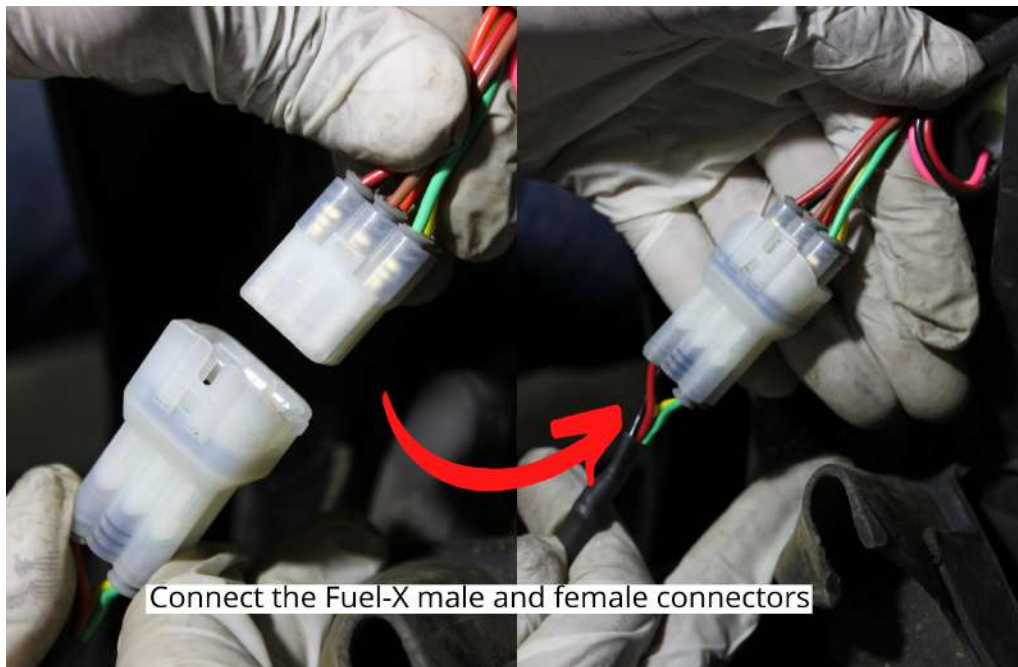

#### 4.2 Attaching the panels fairing etc

Attach the panels, fairing as removed from the bike. And fit the provided map switch at an accessible place available on the handlebar.

## 5. FuelX Configuration

The Red LED on the FuelX blinks once the FuelX activates.

For Pro versions, maps on the FuelX can be changed according to the preference of the customer. By just pressing the +/- button on the Handlebar map switch. **The green LED on the FuelX Handlebar map switch will help the customer to know which map is currently active.**

Map No	Map Description
1	LEAN (Less Fuel)
2	
3	STOCK
4	
5	
6	
7	
8	
9	
10	RICH (More Fuel)

Image 5.1

The rider can choose the map according to the fuel enrichment he wants. The first two maps are lean maps.

Map 3 runs with stock AFR set by the OEM manufacturer.

Maps 4 from 10 make the AFR richer as the numbers go higher.

For Lite versions, a single autotune map is provided for adjusting the AFR for the best operational parameters.