

FuelX Autotune- KTM Duke 390 2024

| | | | |
|-------------------------|---|---------------------|---------------|
| Document Version | 1 | Release Date | 09 April 2024 |
|-------------------------|---|---------------------|---------------|

| | |
|--------------------------------|-----------------|
| Application information | FuelX |
| Vehicle | KTM |
| Model | Duke 390 |
| Year of manufacture | 2024 |

Note:

- Read through all instructions before installation and use.
- Ensure that the bike is switched off and the key is out of the ignition before proceeding with the installation.
- Some parts of the bikes might be hot/sharp and may cause burns/cuts. Proceed with extreme caution or wait until the bike has cooled down. Always wear safety gloves.
- When the installation is complete, make sure to secure the wiring loom away from the movable parts or components which tend to heat up during the normal operation of the vehicle at any chance.
- FuelX is intended for motorsport use on a closed course, please check with your local laws before using this product. Race Dynamics is not liable for consequences arising out of using the product.

Support:

North & South America : +1 267 214 9292 (Call) +91 9606 044 178 (WhatsApp)

India, Bangladesh, Bhutan, Srilanka & Nepal : +91 9916 229 292 (Call & WhatsApp)

Rest of the world : +91 9606 044 177 (Call & WhatsApp)

Email : support@powertronicecu.com

Website : www.powertronicECU.com



for Indian specification vehicles, the FuelX module will have a sticker indicating it.



The warranty/support will not be provided for international users with Indian specification FuelX purchased from unauthorized re-sellers.

| SL No | Chapter | Page |
|-------|----------------------------------|------|
| 1 | About FuelX and Kit Contents | 3 |
| 2 | FuelX Variants | 4 |
| 3 | FuelX Connectors | 5 |
| 4 | FuelX Installation | 7-20 |
| 5 | FuelX Configuration and Settings | 21 |
| 6 | FuelX LEDs | 22 |

Tools required

| Serial No | Main tools | Optional tools |
|-----------|--|--------------------------------|
| 1 | 4mm, 5mm Hex bit | Spinner handle |
| 2 | 10mm, 8 mm T bar Hexagonal Socket wrench | Ratchet handle |
| 3 | Wirecutter | Extension bar or Sliding T-bar |

1. FuelX

FuelX is an electronic, plug-in, fuel-injection optimizer for modern engines. It either enriches or decreases the AFR in all operating regions according to the rider requirement. It autotunes the engine to best operational parameters, constantly monitoring, learning, and adapting to the engine condition, wear and tear, riding style, add-ons (such as air filter and/or exhaust), etc as well as the environmental conditions such as temperature, humidity, altitude, etc. always ensuring the engine performs in the safest and most optimal zones.



FuelX kit contains the following items

- FuelX Module
- Wiring Harness
- Handlebar map switch (Pro and Pro+ version only)
- Zip ties
- Decals
- Quick start guide and Warranty card



Image 1.1

2. FuelX Variants:

FuelX Pro+

The FuelX Pro+ variant has 10 maps that can be changed depending on the preference of the rider. For the Pro+ version, the FuelX contains an additional connector (Refer to Image 2.3) for the Handlebar Map switch (Refer to Image 2.2).



Image 2.1



Image 2.2

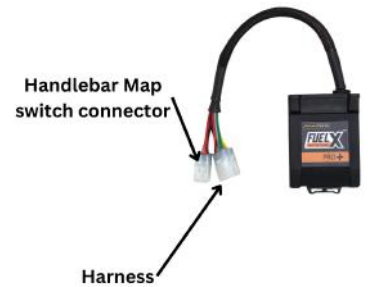

Image 2.3

FuelX Pro

The FuelX Pro variant has 10 maps that can be changed depending on the preference of the rider. For the Pro version, the FuelX contains an additional connector (Refer to Image 2.6) for the Handlebar Map switch (Refer to Image 2.5 m)



Image 2.4



Image 2.5

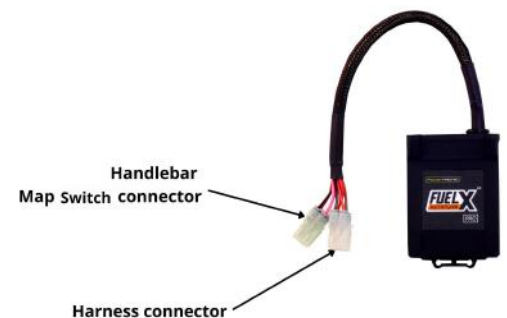

Image 2.6

FuelX Lite

The FuelX Lite variant has a single autotune map and only one connector for the harness.



Image 2.7

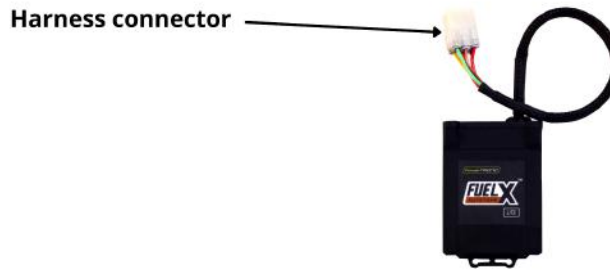

Image 2.7

3. FuelX Harness Connectors

The harness contains

- The Lambda connector (O₂)
- FuelX connector
- Ground/battery negative connector.

The FuelX is connected between the Lambda sensor connector and the ECU. The male connector of FuelX is connected to the female of the Lambda sensor and vice versa.

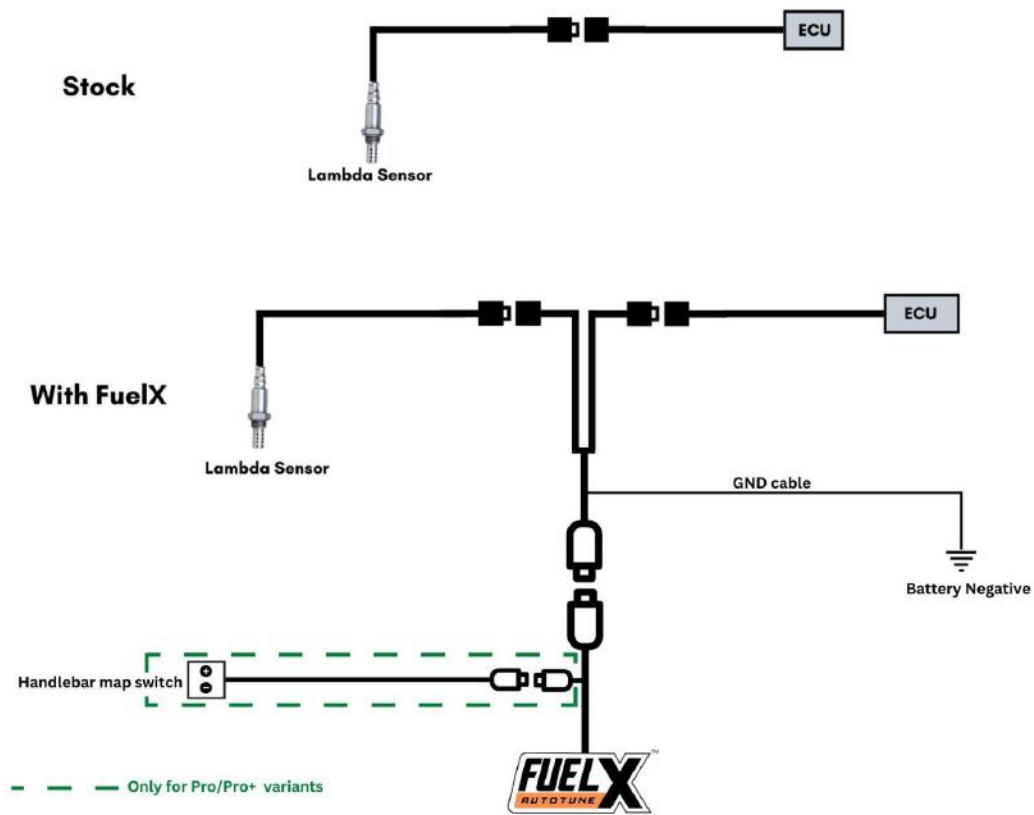

Image 3.4

4. Installation procedure

4.1 Removing panels, fairing

Park the bike using the center stand on a level surface (Or a paddock stand). Refer to [Image 1](#)



Image 1

4.1.1 Detach the pillion seat by inserting the key into the keyhole shown in **Image 2**, and unlock the pillion seat. **Image 3** shows the pillion seat detached.



Image 2



Image 3

4.1.2 Detach the rider seat. (Gently lift and slide it towards the rear end - Refer to **Image 4**).



Image 4

4.1.3 Locate the tank rear mounting bolts (4 nos). Refer to **Image 5**



Image 5

4.1.4 Unscrew the tank rear mounting bolts using 4mm Allen key. Refer to **Image 6**



Image 6

4.1.5 Locate and unscrew the tank front mounting bolts using a 14mm Hexagonal socket. Refer to **Image 7** and **Image 8**



Image 7



Image 8

4.1.6 Gently lift the tank front and locate the canister. Gently unplug the canister from the slot. Refer to **Image 9**.



Image 9

4.1.7 Locate and unplug the Vacuum hoses from the tank. Refer to **Image 10**



Image 10

4.1.8 Detach Fuel plump connector. Refer to **Image 11**.



Image 11

4.1.9 Locate and gently detach the Fuel Line. Refer to **Image 12**.



Image 12

4.1.10 Locate and gently detach the Bank angle sensor from the left side panel. Refer to **Image 13**.



Image 13

4.1.11 Gently lift the tank assembly and place it safely. Refer to **Image 14**



Image 14

4.1.12 Remove the battery-relay box cover. Refer to **Image 15**



Image 15

4.1.13 Locate the stock Lambda connector of the vehicle. Refer to **Image 16**

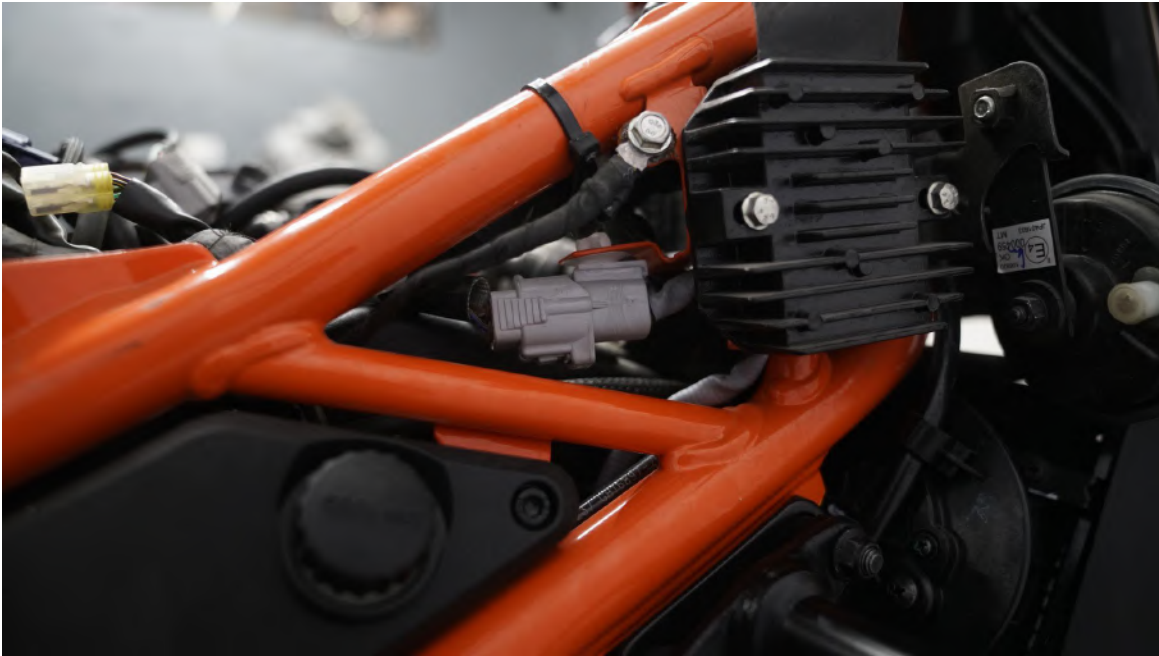

Image 16

4.1.14 Disconnect the Lambda connector of the vehicle. Refer to **Image 17**



Image 17

4.1.15 Connect the FuelX male Lambda connector to the stock female Lambda connector of the vehicle. Refer to **Image 18**



Image 18

4.1.16 Connect the FuelX female Lambda connector to the stock male Lambda connector of the vehicle. Refer to **Image 19**



Image 19

4.1.17 Route the FuelX harness to the rear end of the vehicle. Refer to **Image 20**



Image 20

4.1.18 Connect the ground terminal connector to the negative terminal of the battery. Refer to the **Image 21**



Image 21

4.1.19 Using a 2.5 mm Allen key, tighten the bolts of the handlebar map switch. Refer to **Images 22 A and 22 B**



Image 22A, Image 22B

4.1.20 Route the handlebar map switch harness to the rear end of the vehicle. Refer to **Image 23**



Image 23

4.1.21 Keep the FuelX module in the glove box. Refer to **Image 24**



Image 24

4.1.22 Connect the FuelX 6-pin female connector to the harness 6-pin male connector. Refer to **Image 25**



Image 25

4.1.23 Connect the FuelX 4-pin female connector to the handlebar map switch harness 4-pin male connector. Refer to **Image 26**



Image 26

4.1.24 Use zip ties to secure the harness wherever necessary. Attach the panels back. The installation is complete and you can use the FuelX.

5. FuelX Configurations and Settings

For Pro versions, maps on the FuelX can be changed according to the preference of the customer. By just pressing the +/- button on the Handlebar map switch. The **Green LED** on the FuelX Handlebar map switch will help the customer know which map is active. Ie the number of blinks on the handlebar switch indicates the number of maps.

| Map No | Map Description |
|--------|------------------|
| 1 | LEAN (Less Fuel) |
| 2 | |
| 3 | STOCK |
| 4 | |
| 5 | |
| 6 | |
| 7 | |
| 8 | |
| 9 | |
| 10 | RICH (More Fuel) |

Image 5.1

The rider can choose the map according to the fuel enrichment he wants.

The first two maps are lean maps.

Map 3 runs with stock AFR set by the OEM manufacturer.

Maps 4 from 10 make the AFR richer as the numbers go higher.

For Lite versions, a single autotune map is provided for adjusting the AFR for the best operational parameters.

6. FuelX LEDs

FuelX has LEDs on the module to indicate the operation.

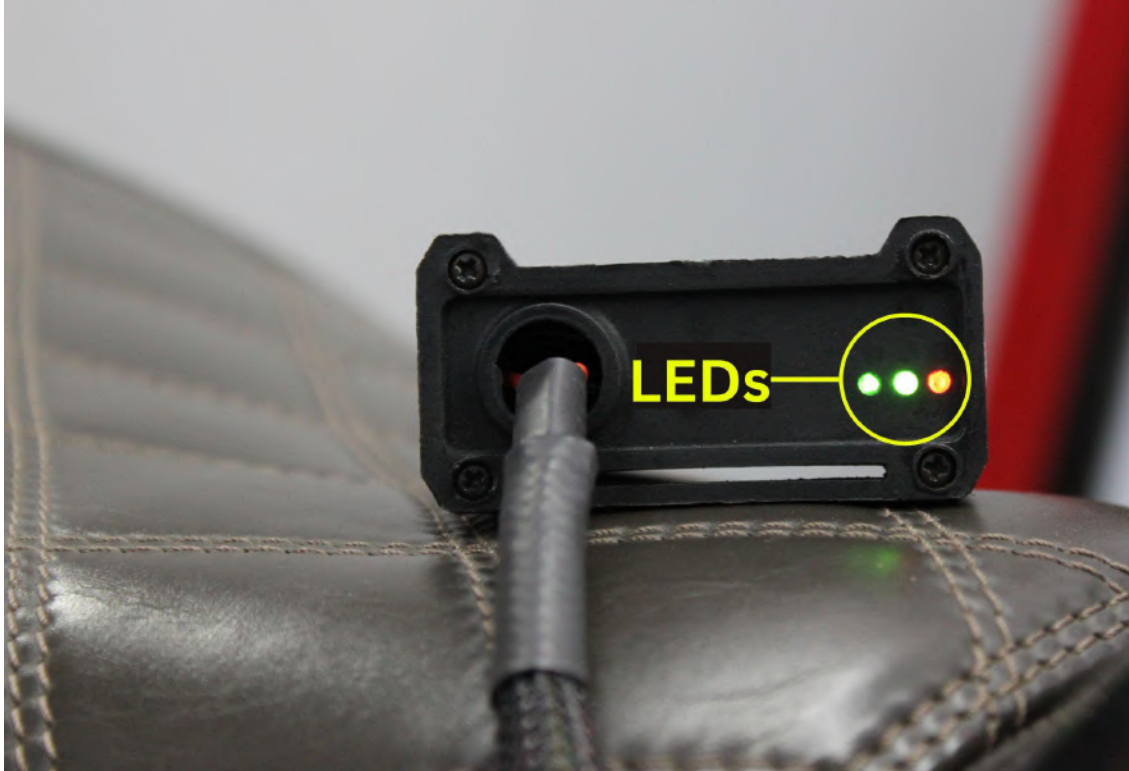

The blinking of the **Red LED** indicates that the Map on the FuelX is being activated. The Red LED starts blinking after the key and the kill switch are on.

The blinking of the **Green LEDs** during the idling of the engine indicates that the FuelX is working in sync with the OEM ECU.

The working of both Green and Red LEDs indicates the FuelX Functioning as intended.